

STEP 1-1 Rotor Head Block

Sub Assembly 1 Main Rotor Head

From parts bag 1: Press the Damper Rubbers and the Guide Pins into the Head Block. Apply one drop of thin CA glue to the pins after they are fully seated. Install one M3x10 oilite bearing onto each side of the seesaw shaft and insert into the Head Block. Secure with the two M3x6 self tapping screws.

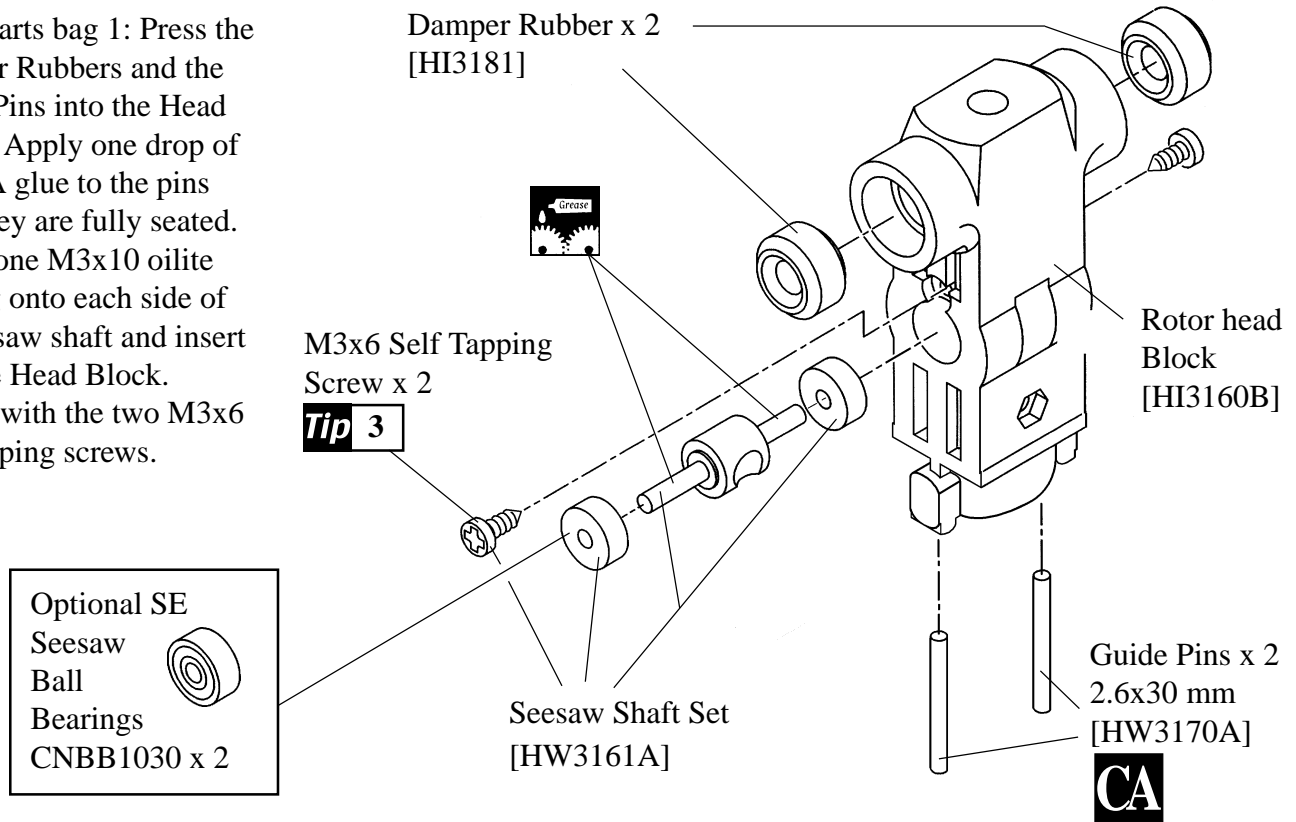

STEP 1-2 Seesaw Assembly

From parts bag 1: Insert one 3x7mm ball bearing into each bearing cup and insert into the offset plate. Following the numbered order, thread one M3x6 Button Head Screw and one M3x6 Special ball through the offset plates into one tie bar. Slide the assembly onto the seesaw shaft and attach the other tie bar from the opposite side.

