

STEP 5-1 Rotor Head Assembly

Final Assembly

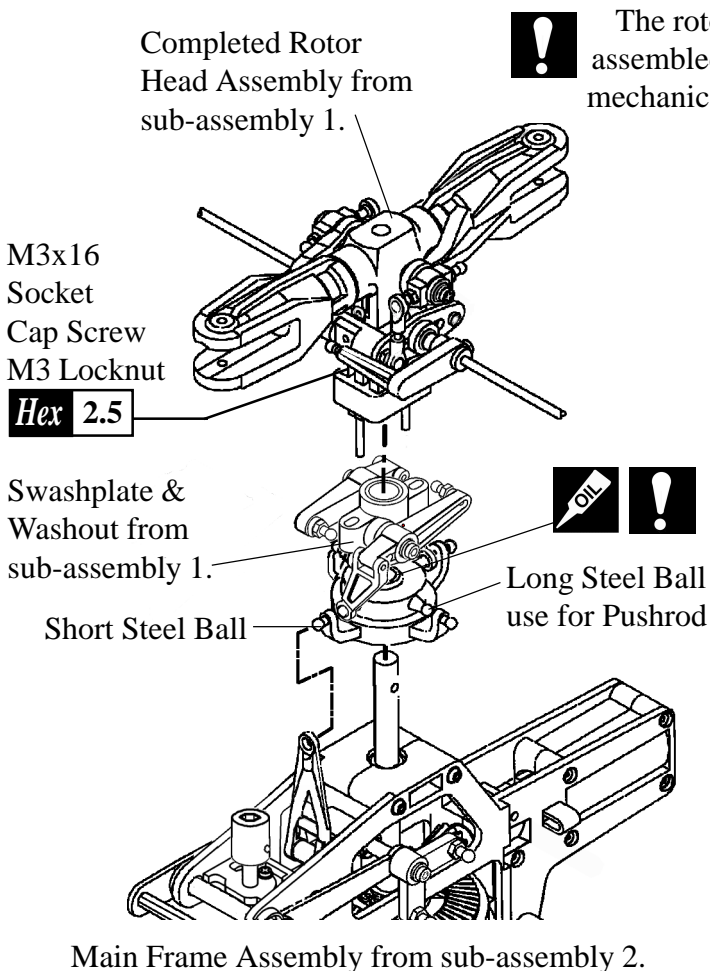

! The rotor head assembly with washout and swashplate should be assembled now to complete all the pushrods for the main head and mechanics. Once the radio installation is complete, it will be disassembled as in this step to be fitted to the scale fuselage.

Remove the M3x16 Socket Cap Screw from the top of the main shaft. Slide the swashplate and washout assembly from **sub-assembly 1** onto the main shaft and snap the elevator lever arm onto the single front ball on the swashplate. Slide the completed rotor head assembly from **sub-assembly 1** onto the shaft and align the hole in the head block with the hole in the top of the main shaft. Insert the M3x16 Socket Cap Screw and M3 locknut to secure the two.

(Note: Make sure the pins in the rotor head block are aligned and inserted into the holes in the washout unit.) Apply some oil sparingly to the washout hub assembly to insure they slide smoothly.

Following assembly, move the collective lever fore and aft to the endpoints. The swashplate and washout unit should be very smooth throughout the movement range. If not, inspect the fit of the washout guide to the pins in the rotor head, these pins can be bent slightly if binding. Also check the collective axle, the screws here may be too tight. The fit of the ball links sometimes can cause binding, with time these will break in. These few points are the most common which will cause servo strain leading to premature wear and can make the collective control a little vague.

Idle adjustment is nearly impossible without [CN2030] Idle Mixture Screw (not included) extensions. We recommend using them

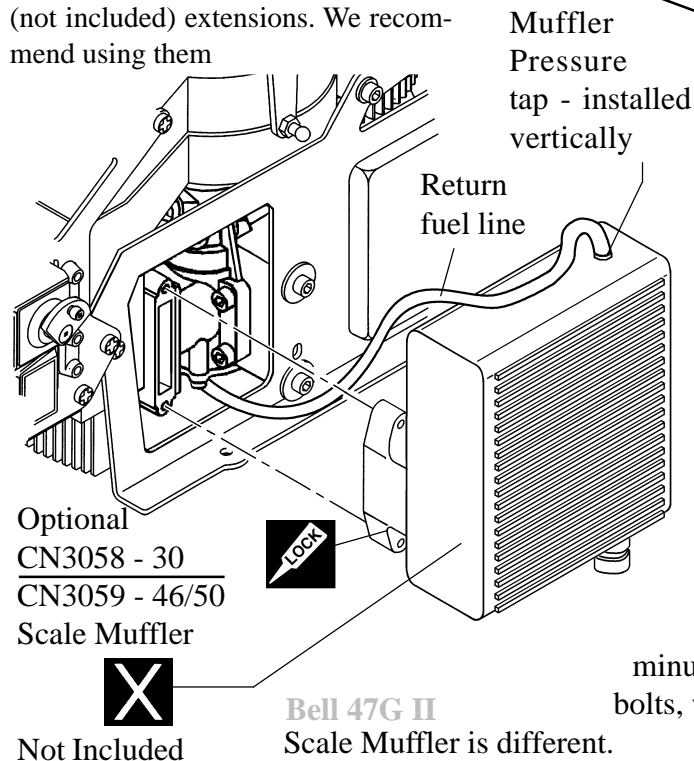

STEP 5-2 Attaching the muffler

With the narrow space between the mechanics and the fuselage, it is recommended to install the scale muffler Century has designed for these helicopter fuselages. Attach the muffler to the engine with the screws provided with the muffler (**Tip 1**- using hi-temp threadlock). Attach the pressure tap to the top of the muffler, remember to use hi-temp RTV sealer or threadlock on these parts. Route the return fuel line below the engine.

Tip For a good seal between the muffler and the exhaust port, use a gasket made from thin aluminum, brass or exhaust gasket material.

To properly seal the fit, after running the engine for several minutes on the first run, shut down the engine and re-tighten the bolts, while the engine is still hot. The extra 1/8 to 1/4 turn on the bolts will seat the muffler in place. Do not strip the holes!