

STEP 4-6 Tail Rotor Grips & Tail Rotor Pitch Lever

Sub Assembly 4 Tail Boom

From parts bag 7: Using threadlock on the two M2x10 Phillips Machine Screws and M2 Hex Nuts, assemble both Blade Grip Halves over the bearings with the nuts facing towards the gearbox, snap the two balls from the tail rotor grip into the adjoining pitch slider links.

Install the Tail Rotor Blades using two M3x16 Socket Cap Screws and M3 locknuts. Note the direction of the blades on the diagram, the straight leading edge of the blade should be on the same side as the ball on the blade grip.

Install the M2 Short Steel Ball, threaded from the bottom of the bellcrank. Install the tail rotor bellcrank onto the tail rotor gear box with one M3x16 Socket Cap Screw, inserted through the bushing with the washer side on the bottom (**make sure the steel ball at the bottom of the pitch slider is engaged into the end of the t/r bellcrank**). Do not overtighten the M3x16 bolt.

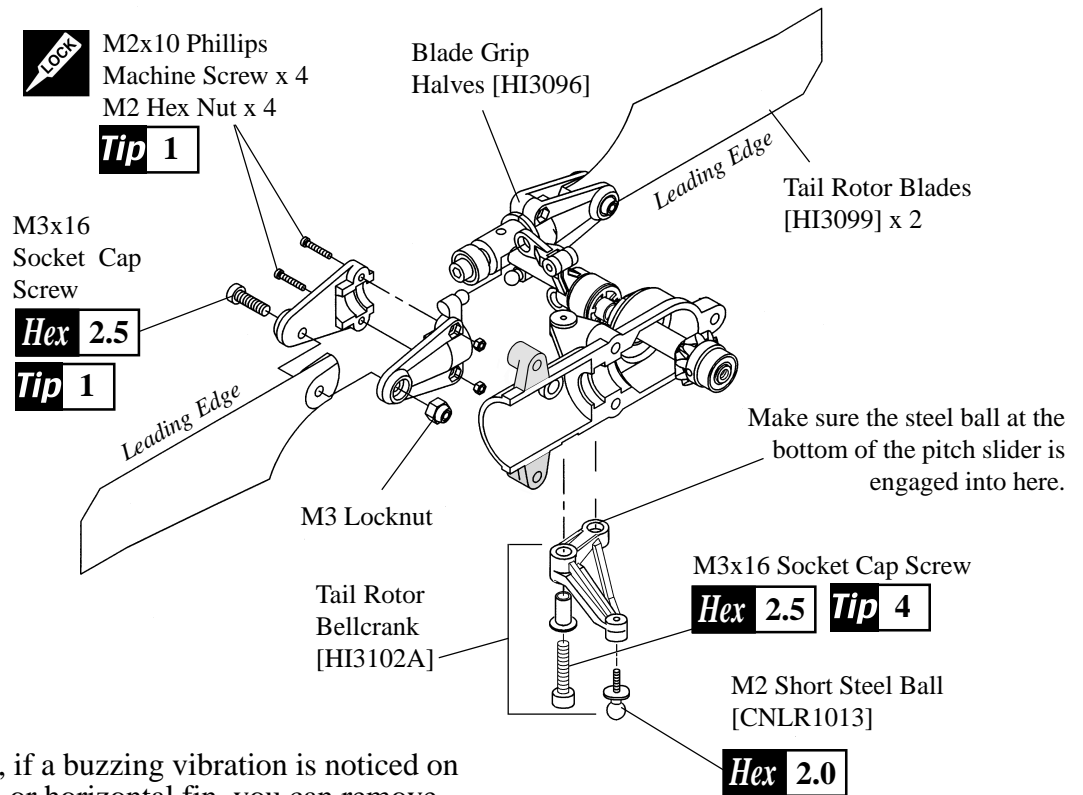

After flying the model, if a buzzing vibration is noticed on the ends of the vertical or horizontal fin, you can remove the complete tail rotor assembly with the hub and further balance it using a High Point balancer. Careful sanding of the rotor blades is all that would be needed.

Tip

STEP 4-7 Tail Drive Shaft Preparation

Packed with the tailboom: The Tail Drive Shaft has one end flattened to engage into the front of the mechanics, the other end needs to have a 20mm long flat spot filed on the round end of the shaft to provide a more solid seating for one of the two M4x4 Set Screws on the tail rotor input shaft.

Put a flat spot on the the round end of the Tail Drive Shaft.

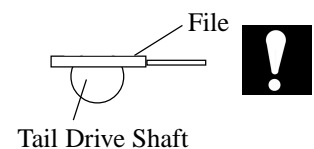
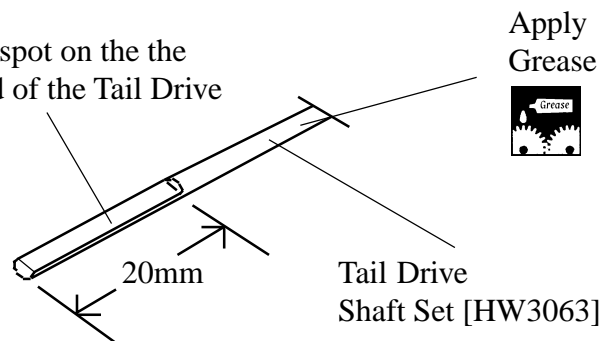

Tip

A flat file is the ideal tool for the job, alternately careful use of a Dremel Moto Tool will work. It is important that the flat be at least 1/4 of the diameter but no more than 1/3 to avoid weakening the material.