

STEP 16-17 Clutch, Fan & Engine Mounting

STEP 16 From parts bag 3.

Remove all parts from the engine crankshaft until you can see the front ball bearing, install the 9x14mm Flat washer (or washer provided by engine manufacturer), insert the Ball Bearings into the clutch bell assembly and place on the crankshaft. Clean the threads (**Tip 1**) on the crankshaft and on the clutch, carefully apply threadlock on the engine crankshaft threads nearest the bearing (be careful not to get threadlock into the ball bearings) and on the threads in the clutch. Thread the clutch until the crankshaft can be seen and insert the fan keying it to the clutch. Wrap a cloth over the fan (provides grip to the fan without breaking the fins) and tighten until the clutch stops, torque an additional 1/16 of a turn. Using a Piston Lock [CN2155 Optional Parts] makes this easier. Secure the fan by placing one 6.5x13mm Washer and apply a liberal amount of threadlock to secure the nut that came with the engine from the inside of the fan assembly. Again only torque the nut 1/16th more.

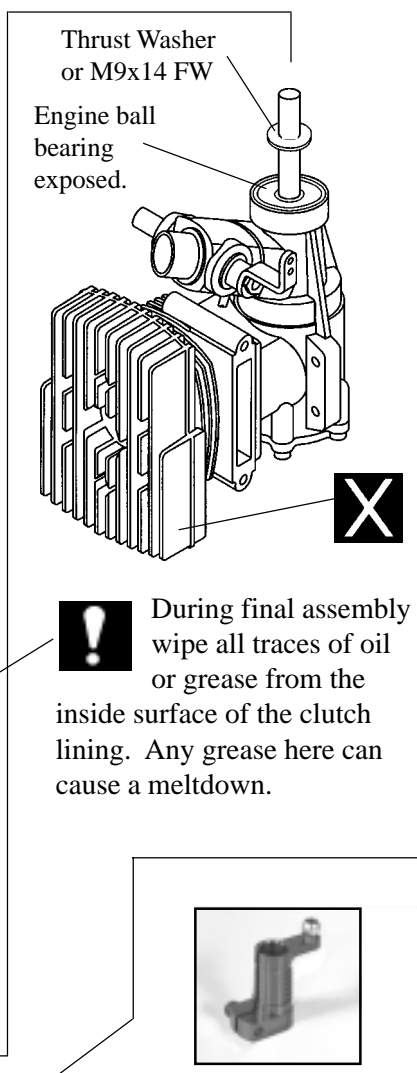
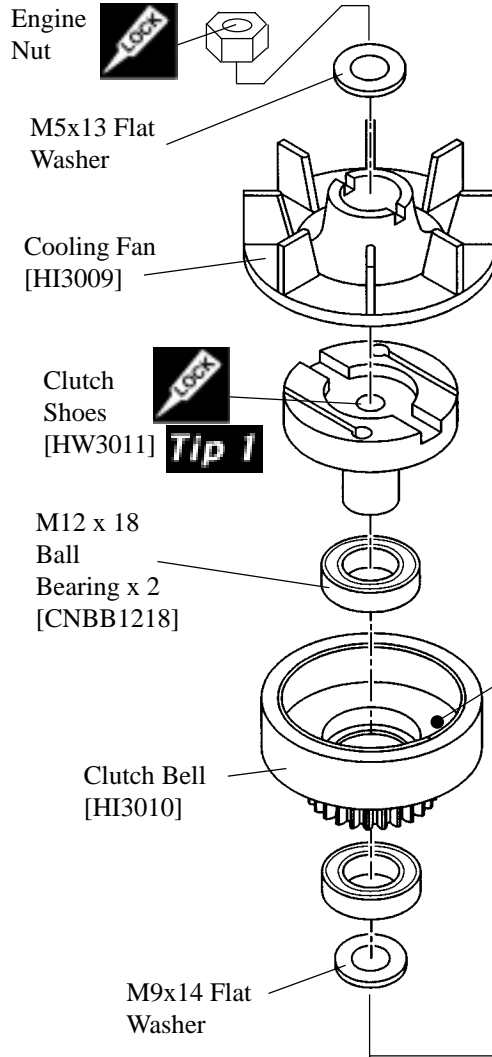

STEP 17

Secure the engine assembly on to the engine mount using four 3x16mm Socket Cap Screws using threadlock. From bag 4, install the Throttle Extension by removing the arm supplied on the engine. The arm has to be repositioned to get equal throw, both open and closed from 50%.

(Optional Parts)
CN2153 Throttle Extension for OS28-32FH,SX & TT36H

