

# STEP 13 Upper Side Frames

## STEP 13

From parts bag 2, install two 4x5mm Set Screws (**Tip 1**) on the Mast Stopper then slide the mast stopper on the main shaft followed by one M8x19 Ball Bearing on the bottom of the main shaft and one M10x19 Ball bearing from the top.

Attach the starter shaft assembly with four 3x12mm Self Tapping Screws<sup>1</sup> (**Tip3- observe the correct direction of the block assemblies**). Position the auto rotation gear assembly, the counter gear assembly and the tail transmission output shaft assembly at the locations on the diagram into the upper right side frame ( **Make sure the bearings are fully seated in the recesses.** )

M3x12 Self Tapping  
Screws x 4

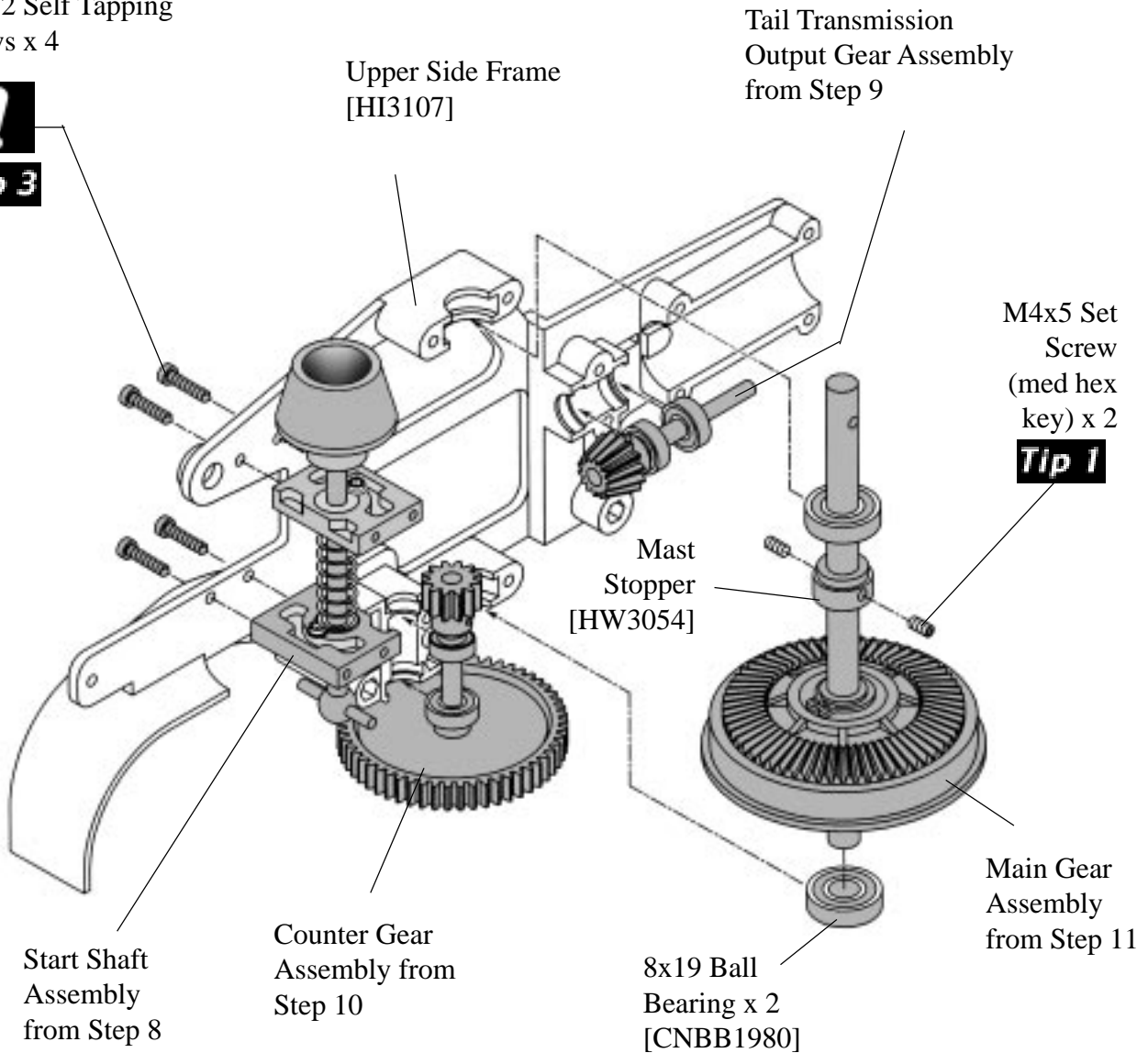
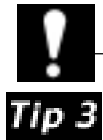

**Note 1:** Be careful when tightening the eight 3x12mm self tapping screws into the start shaft block assemblies as excessive force will strip out the plastic holes.