

## STEP 42 Elevator Linkage

The elevator pushrod controls the tilt of the swashplate forward and backward which causes the helicopter to pitch forward or backward ( hence fore-aft cyclic pitch ).

Use a servo horn in the shape of a cross and trim the 3 of the 4 arms off. Using threadlock on the nut only, install one steel ball and one M2 Hex nut at a distance of 10mm from the center of the servo. With the radio on and the elevator trim set at the center, attach the elevator pushrod (E) to the elevator bellcrank, then attach the servo horn at an angle of 10-15 degrees behind center of the servo (towards the front), the offset enables an equal throw of the swashplate. **It is important that the swashplate sit at 90 degrees to the main shaft when viewed from the side.**

**Tip** When trimming the helicopter for stable and stationary hovering using the electronic sub-trim on the transmitter, typically the elevator servo is labeled backwards. Conventions typically use U for up and D for down. Intuition tells you that if the helicopter is moving backwards then a little U-up trim is needed. Be careful, as in reality to trim the elevator to stop the backwards movement, the value for D-down needs to be increased.

**Tip** We have repeated mentioned to only use threadlock on the nut only for the steel control balls for the servo horns. The reason is the plastic used in the servo horns becomes very brittle when regular locktite is used, it is better to make sure it does not contact the plastic.

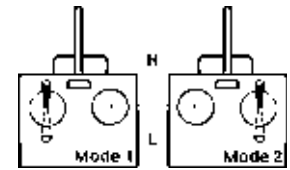

As the elevator stick is moved upwards the elevator pushrod will move backwards tilting the swashplate forwards.

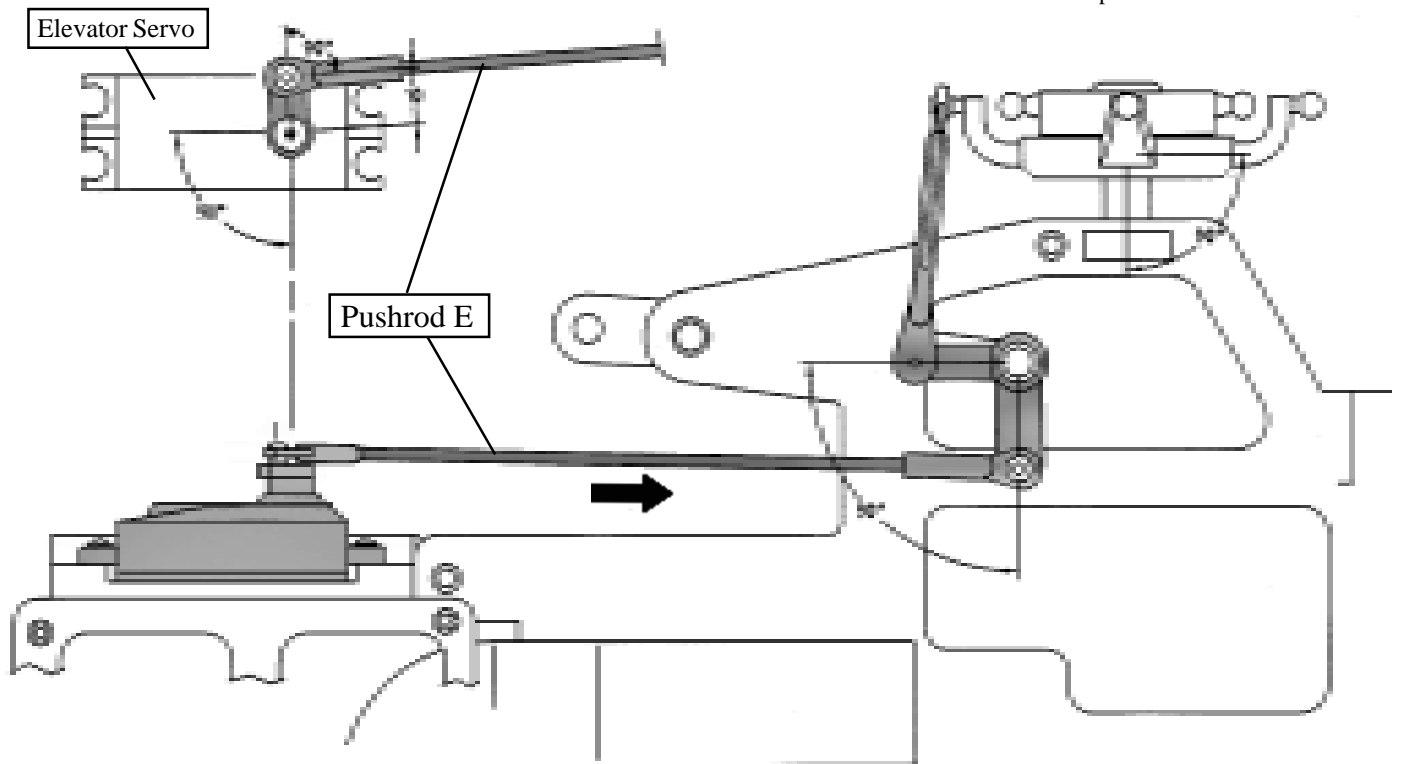

Steel Ball for Servos  
[CNLR1013]



Install one steel ball into the servo arm on top secured with one M2 Hex nut.