

## STEP 20 Upper & Lower Frames

Using threadlock, attach the lower frame assembly to the upper frame assembly with four M3x16 Socket Cap Screws and four M3x7 Washers.

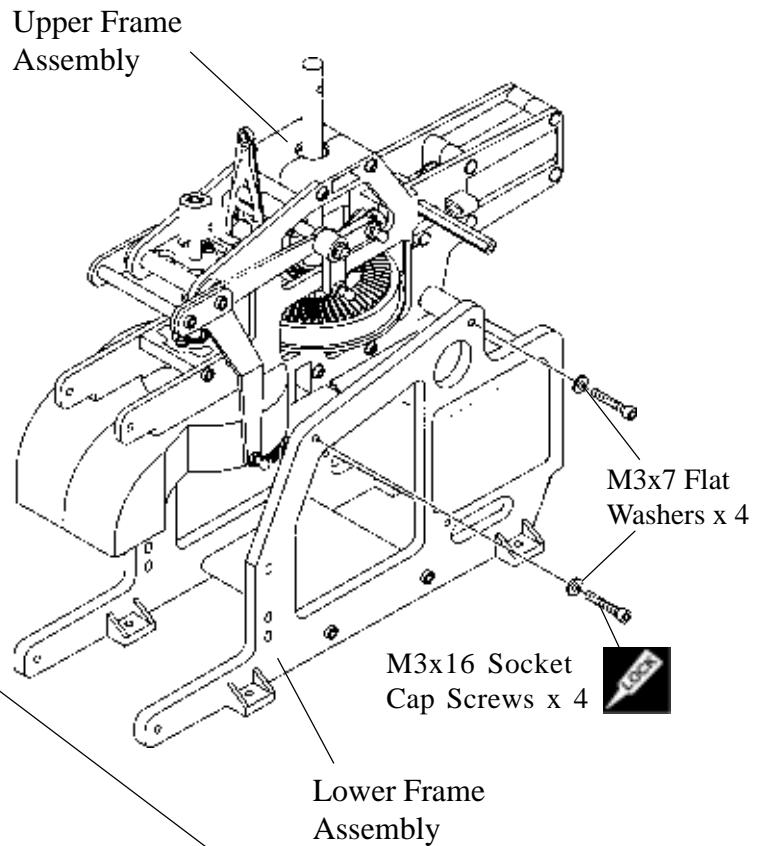

## STEP 21 Engine Cooling Fan Shroud

Assemble the Lower Cooling Fan Shroud over the head of the engine using parts from bag 3. Assemble the two halves using the five M2.6x10 Self Tapping Screws. Loosely install the engine assembly into the lower side frames using four 3x16mm Socket Cap Screws and four 3x7mm Large Flat Washers. Position the lower shroud to overlap the upper shroud, adjust the engine height by sighting from the side. Slide the engine upwards until the clutchbell gear is properly meshed with the counter gear, then threadlock the screws in place. At this time, plug the fuel line to the carburator (**Tip 1** -installing a fuel filter between tank and carburator will help prevent any fuel contamination from entering the carburator and causing engine failure). Now check the starting shaft, loosen the collar and adjust its height to insure the start shaft can fully disengage from the cooling fan. **NOTE:** use threadlock on set screws of collar.

