

STEP 14 Upper Frame Assembly

From parts bag 2: Insert the two long Hex Spacers at the specified locations in the diagram (**note: the front hex spacer is installed into the forward-most hole**). Install the upper left side frame, taking care that the bearings are aligned with the mating recesses and secure the frames with four M3x35 Socket Cap Screws (**Tip 1-do not use threadlock when using locknuts**) through the main shaft bearing block positions and four M3 locknuts. It is advised to position the elevator assembly between the side frames at this time in order to reduce the amount of installation positioning later.

While pushing down on the main shaft (make sure the main gear rotates freely), push the mast stopper against the upper ball bearing insuring that the side of the stopper with the raised inner portion is facing upwards, Apply threadlock to the set screws and tighten in place. Attach the remaining four 3x12mm Self Tapping Screws (**Tip 4**) to the starting shaft blocks.

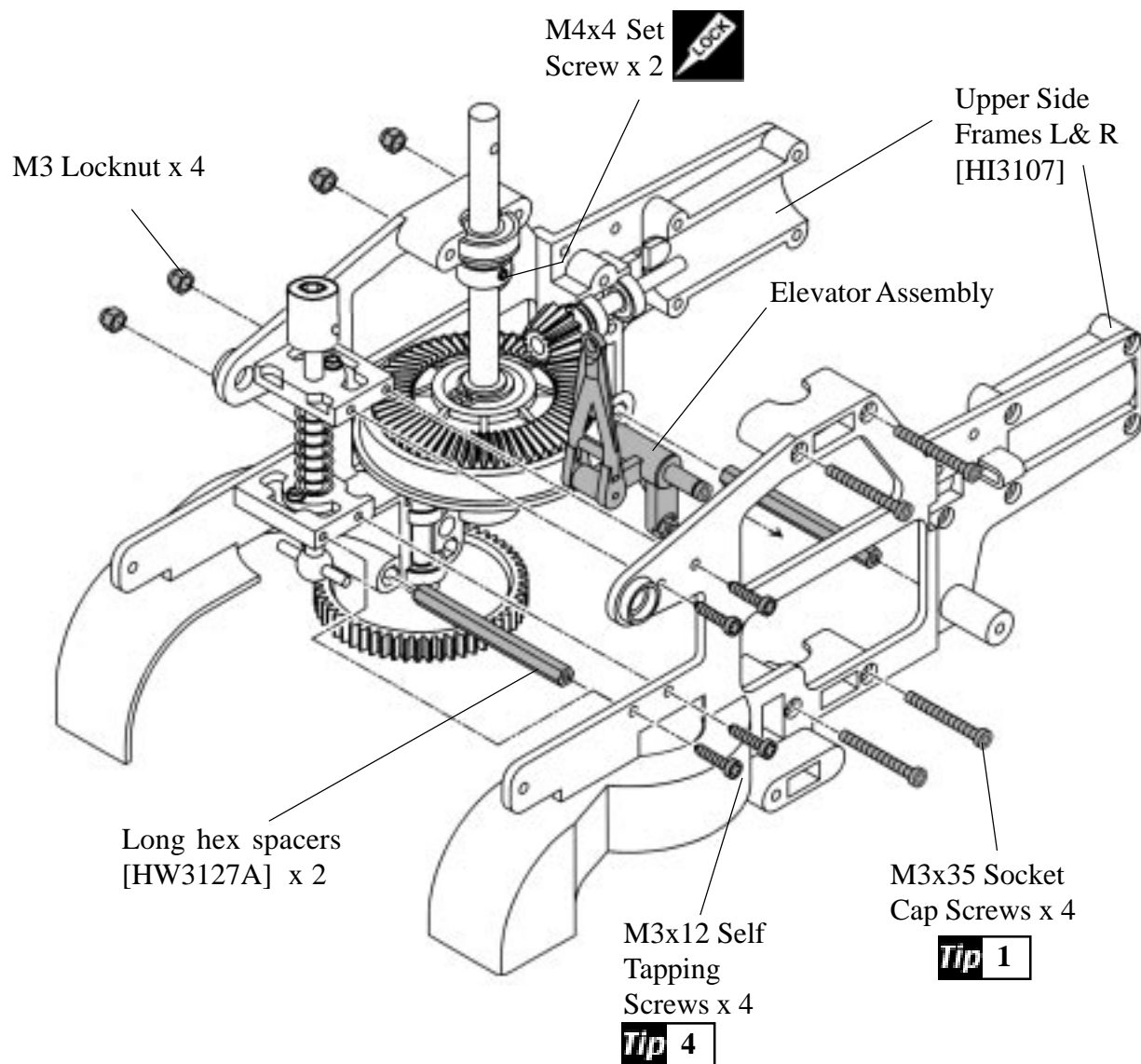

! The gear mesh between the main gear and the tail transmission output shaft may be a snug fit at first, but it will become smooth after a few flights. This is the normal wear in process.